

# Strapack

High Speed Paper/Film Tape Banding Machine

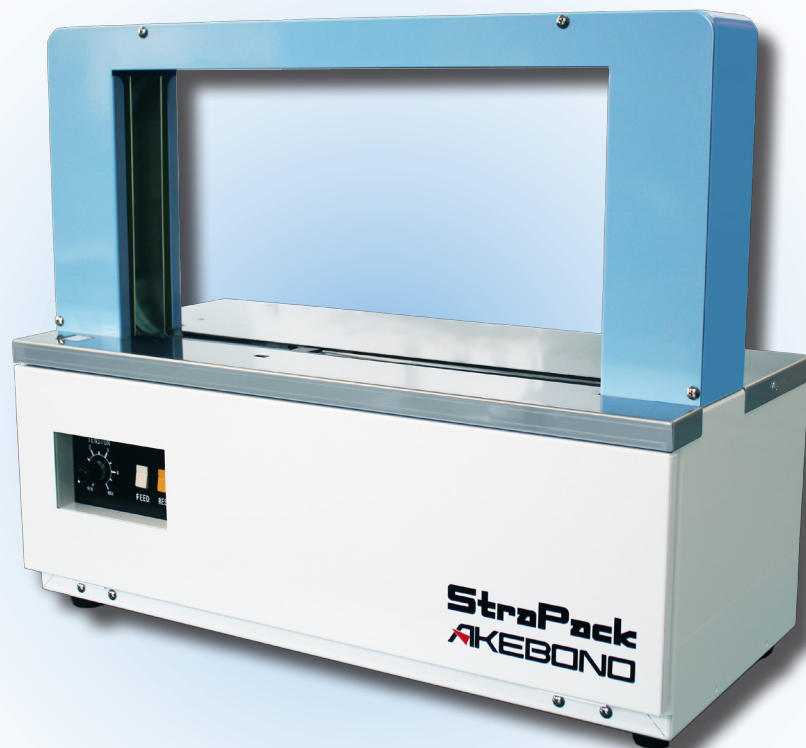

**OB-360N**

# OB-360N



## High Speed Paper/Film Tape Banding Machine

Introducing the new OB-360N. An upgrade from the OB-360, it's more efficient, more versatile, and easier to operate and maintain.

### ■ High Speed

Up to 30 cycles per minute. Soft or elastic bundles can be banded without sacrificing the speed.

### ■ Versatile

-Applies banding to packages as small as 30mm (1-1/8" )wide x 10mm (3/8") high up to 420mm (16-1/2") wide x 210mm (8-1/4") high.

-Either paper or film tape can be used.

-Larger arch size is available upon request.

### ■ Stronger Tension

Tension is easily adjustable, with a volume dial, from 5N to 60N (approx. 1 - 13.5lbsf) to accommodate various applications.

### ■ Better Sealing

Improved sealing/heater design helps achieve an even melting and seamless seal eliminating curled, folded or peeling tape edges.

### ■ Easier Maintenance

The added guide to the tape shooter attachment takes the guesswork out of the reassembly. Along with the built-in Aluminum Sealing Frame, maintenance will be a breeze.

### ■ Friendly Operation

- A cycle can be activated by simply placing a bundle on the table, pressing the Start button or stepping on the foot pedal.

- The Start button has been moved to the table top for easy operation.

- The machine will not operate accidentally without a package on the table.

- In case of feeding issues, the reset function allows the machine to quickly return to its starting position.

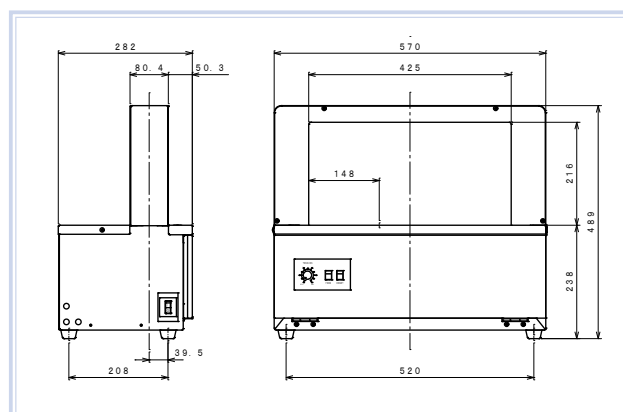

### ■ Standard Specifications

<b>Arch Size</b>		W425 x H220	W16-3/4 X H 8-5/8 in.
<b>Dimension</b>	<b>Width</b>	570 mm	22-1/2 in.
	<b>Height</b>	489 mm	19-1/4 in.
	<b>Depth</b>	282 mm	11-1/8 in.
	<b>Weight</b>	25.5 kg	56-1/4 lbs.
<b>Table Height</b>		238 mm	9-1/4 in.
<b>Min. Package Size</b>		W 30 X H 10 mm	W 1-1/8 X H 3/8 in.
<b>Max. Package Size</b>		W420 X H 210 mm	W16-1/2 X H 8-1/4 in.
<b>Tape</b>		W 30 mm x 190m 80g (paper)	W 1-1/8 in x 623ft 28 ounce (paper)
		W 30 mm x 200-370m 60-110µm (film)	W 1-1/8 in x 656-1214ft 60-110µm (film)
<b>Strap Tension</b>	<b>60µm Film</b>	5-30N (0.5-3 kgf)	1 - 6.6 lbsf
	<b>110µm Film</b>	5-60N (0.5-6.1kgf)	1 - 13.5 lbsf
	<b>80g (28oz.)Paper</b>	5-45N (0.5-4.6kgf)	1 - 10.1 lbsf
<b>Power Supply</b>		100 V 1 Phase 50 / 60 Hz	250 W

Dimensions and specifications are subject to change without notice.

Modification rights reserved.

© 2017 Strapack Corporation

### DISTRIBUTED BY:

STRAPACK CORPORATION  
 8-16-6, Ginza, Chuo-ku, Tokyo, 106-0061, JAPAN  
 Phone: 81-3-6278-1806 Fax: 81-3-6278-1807  
 (URL) <http://www.strapack.com> (E-mail) [info@strapack.com](mailto:info@strapack.com)  
 STRAPACK INC.  
 33508 Central Avenue, Union City, CA 94587-2097 U.S.A.  
 Phone: 1-510-475-6000 Fax: 1-510-475-6090  
 STRAPACK, N.V./S.A.  
 Uilenbaan 200, B-2160 Wommelgem, BELGIUM  
 Phone: 32-(0)3-355-1520 Fax: 32-(0)3-355-1521